

# Dissimilatory Nitrite and Nitric Oxide Reductases

Bruce A. Averill\*

*E. C. Slater Institute, University of Amsterdam, Plantage Muidergracht 12, 1018 TV Amsterdam, The Netherlands*

*Received March 28, 1996 (Revised Manuscript Received September 3, 1996)*

## Contents

I. Introduction	2951
II. Fundamental Considerations	2953
III. Dissimilatory Nitrite Reductases	2953
A. Heme <i>cd</i> <sub>1</sub> -Containing Nitrite Reductases	2954
B. Copper-Containing Nitrite Reductases	2957
IV. Nitric Oxide Reductases	2959
A. Bacterial Nitric Oxide Reductases	2959
B. Fungal Nitric Oxide Reductases	2961
V. Conclusions	2962
VI. Acknowledgments	2963
VII. References and Notes	2963



Bruce A. Averill was born in Ohio in 1948 but grew up in New England. He received a B.S. in chemistry from Michigan State University in 1969. This was followed in 1973 by a Ph.D. in inorganic chemistry with Dick Holm at M.I.T., where he was an NSF predoctoral fellow. He subsequently spent 3 years learning biochemistry on NSF and NIH postdoctoral fellowships with Bob Abeles at Brandeis University and Bill Orme-Johnson at the University of Wisconsin, Madison. In 1976, he returned as an assistant professor of chemistry to Michigan State University, where he was named an Alfred P. Sloan Foundation Fellow and promoted to associate professor in 1981. The next year, he moved to the University of Virginia, where he was promoted to professor of chemistry in 1988. During his time at Virginia, the focus of his research shifted more toward studies of metalloenzymes. In 1994, he moved to the E. C. Slater Institute of the University of Amsterdam as a professor of biochemistry, specializing in biocatalysis. His research now focuses on the structure and mechanism of iron-containing phosphatases and the enzymes of denitrification.

## I. Introduction

The inorganic nitrogen cycle (Figure 1) consists of several linked biological processes and one abiological process, the reaction of  $N_2$  and  $O_2$  in lightning discharges and internal combustion engines to produce  $NO_x$  and, ultimately, nitrate. All of the processes except nitrogen fixation involve reduction or oxidation of species containing N–O bonds of order greater than 1, such as  $NO_3^-$ ,  $NO_2^-$ , NO, and  $N_2O$ .

Denitrification is the anaerobic use by bacteria of nitrogen oxide species as terminal electron acceptors in place of  $O_2$ .<sup>1,2</sup> It is important because it constitutes the only process that returns large amounts of fixed nitrogen to the atmosphere, thereby completing the terrestrial nitrogen cycle (Figure 1). It is also important commercially in that denitrification, by itself or in combination with nitrification, can result in the loss of up to 30% of fixed nitrogen fertilizer.<sup>3</sup> Further, denitrification is a “leaky” process under many conditions, resulting in the release of large amounts of  $N_2O$ , a greenhouse gas that is also implicated in atmospheric ozone depletion,<sup>4</sup> into the atmosphere. Denitrifiers are potentially of great importance in bioremediation efforts,<sup>5</sup> since dissolved nitrate concentrations are often easier to control than are oxygen concentrations. In addition, denitrifiers have important potential applications in wastewater remediation, as evidenced by the use of immobilized nitrate, nitrite, and nitrous oxide reductase enzymes for electrochemical<sup>6</sup> or biochemical<sup>7</sup> removal of nitrate from water. Finally, the well-studied enzymes of denitrification provide potential structural and spectroscopic models for mammalian enzymes that produce and utilize NO in a variety of signal transduction pathways.<sup>8</sup>

Denitrification is a basic physiological process that is crucial for energy generation in the survival of a

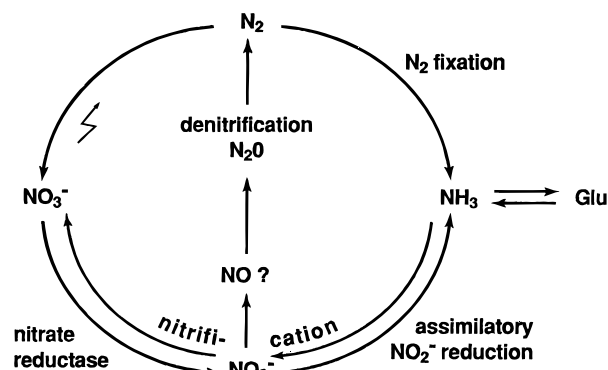
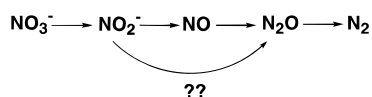

**Figure 1.** Inorganic nitrogen cycle, showing the central position of denitrification.

variety of bacteria.<sup>2</sup> Denitrifying bacteria occupy a wide range of natural habitats, including soil, water, foods, and the digestive tract.<sup>9–11</sup> Although these organisms prefer oxygen as an electron acceptor, in the absence of oxygen they can obtain energy from electron transport phosphorylation coupled to the reduction of nitrogen oxide species ( $NO_3^-$ ,  $NO_2^-$ , NO,  $N_2O$ ).<sup>2,9,10,12</sup>

Before proceeding further, it is important to distinguish denitrification from two other physiological

\* Phone: 31-20-525-5045. Fax: 31-20-525-5124. E-mail: BAA@CHEM.UVA.NL.

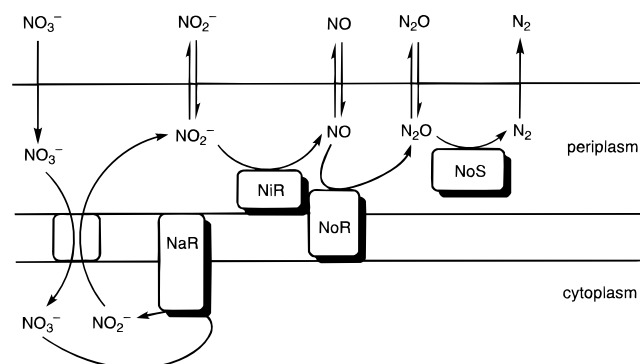

**Figure 2.** Pathway of denitrification, with NO as an obligatory free intermediate. In some organisms under some conditions, conversion of nitrite to nitric oxide via the copper-containing nitrite reductases may occur as shown, but this remains controversial.

processes that also involve the reduction of nitrite, but to ammonia rather than to gaseous  $\text{N}_2$  or nitrogen oxides.<sup>13</sup> Certain bacteria, including *Wolinella succinogenes* and *Vibrio fischeri*, carry out what appears to be a dissimilatory reduction of nitrate to ammonia, which is then secreted into the medium. The key enzyme in the species examined to date is a relatively small (50–60 kDa) hexaheme *c* protein<sup>14</sup> that reduces nitrite directly to ammonia with no free intermediates detectable. A superficially similar reaction is carried out by the assimilatory nitrite reductases found in plants and in certain bacteria, which also reduce nitrite directly to ammonia with no detectable intermediates.<sup>13</sup> In this case, however, the ammonia produced is utilized for biosynthetic purposes rather than being secreted. The assimilatory nitrite reductases contain an  $\text{Fe}_4\text{S}_4$  cluster linked to an unusual reduced heme, an isobacteriochlorin referred to as siroheme. Available data on these enzymes suggest that they are very similar to the assimilatory sulfite reductases, which carry out the analogous six-electron reduction of sulfite to sulfide. A high-resolution crystal structure has recently been reported for the *Escherichia coli* sulfite reductase,<sup>15</sup> and in view of their substantial sequence and spectroscopic similarities, it can safely be assumed that the overall features of the assimilatory nitrite reductases are quite similar. Both types of enzyme are important and present interesting mechanistic problems, especially the assimilatory nitrite reductase, which is responsible for nitrogen uptake on a truly massive scale by plants. Their chemistry does not, however, seem to be directly related to that of the enzymes under discussion here.

The overall pathway of denitrification is shown in Figure 2. As shown, a total of four enzymatic steps are involved in most organisms. (A few organisms are known that appear to lack the last enzyme and, consequently, produce  $\text{N}_2\text{O}$  as the major product.) Certain fungi also appear to reduce nitrite to  $\text{N}_2\text{O}$  with the involvement of a cytochrome P450-like enzyme.<sup>16</sup> With the exception of the  $\text{NO}_3^-$  and NO reductases, the enzymes of the denitrification pathway are generally soluble, reasonably easy to obtain in pure form, and exhibit only moderate complexity in terms of their metal cofactor contents.<sup>17</sup> Consequently, the mechanisms of the enzymes of denitrification are in several cases beginning to be rather well-understood.

The major point of controversy in recent years has been whether or not NO is a free obligatory intermediate in the denitrification pathway, or whether nitrite reductases can and do produce  $\text{N}_2\text{O}$  directly from nitrite.<sup>18</sup> The evidence for NO as an obligatory intermediate in denitrification is by now convincing: (i) purified nitrite reductases (NiRs) produce only or mostly NO from  $\text{NO}_2^-$ ; (ii) denitrifiers produce and



**Figure 3.** Arrangement of the enzymes in Gram-negative bacteria: NaR, nitrate reductase; NiR, nitrite reductase; NoR, nitric oxide reductase; NoS, nitrous oxide reductase.

consume NO during nitrite reduction; (iii) denitrifiers produce  $\text{N}_2\text{O}$  from NO with concomitant active transport, proton translocation, and cell growth; (iv) NiRs catalyze the exchange of N between  $\text{NO}_2^-$  and an exogenous NO pool; (v) *nir*<sup>-</sup> mutants retain NO reductase activity; (vi) essentially homogeneous preparations containing high levels of NO reductase have now been obtained; and, perhaps most convincingly, (vii) deletion of the gene coding for the NO reductase protein is lethal in the presence of  $\text{NO}_2^-$ .<sup>1,19</sup> Although certain points of ambiguity remain, it seems clear that the pathway with NO as an obligatory free intermediate is present in all denitrifiers examined to date.

The most important remaining points of ambiguity result from isotope exchange experiments. It has been known for some time that nitrite reductases containing heme *cd*<sub>1</sub> chromophores (vide infra) are capable of catalyzing the exchange of  $^{18}\text{O}$  from  $\text{H}_2^{18}\text{O}$  into NO or  $\text{N}_2\text{O}$  product by a reversible dehydration/hydration reaction of bound nitrite and that an  $\text{E}-\text{Fe}^{2+}-^{15}\text{NO}^+$  species derived from [ $^{15}\text{N}$ ]nitrite could be trapped by nucleophiles such as  $^{14}\text{NH}_2\text{OH}$  or  $^{14}\text{N}_3^-$  to give appropriately labeled forms of  $\text{N}_2\text{O}$ .<sup>20</sup> Unexpectedly, however, it has recently been shown that a similar exchange process occurs during the reduction of NO to  $\text{N}_2\text{O}$  by nitric oxide reductase.<sup>21</sup> If a linear pathway such as that shown at the top of Figure 2 were operative, one would expect that in all cases the amount of  $^{18}\text{O}$  exchange observed with NO as substrate would be less than with  $\text{NO}_2^-$ , since each molecule of  $\text{NO}_2^-$  would have two opportunities to undergo  $^{18}\text{O}$  exchange, once at the  $\text{NO}_2^-$  level and once at the NO level. Although this expectation has been confirmed for many organisms, at least two organisms are known that give precisely the opposite result: *Achromobacter cycloclastes* and *Rhodospseudomonas spheroides* forma sp. *denitrificans* were found to incorporate negligible amounts of  $^{18}\text{O}$  into  $\text{N}_2\text{O}$  starting from  $\text{NO}_2^-$  (4 and 6%, respectively), while incorporating substantial amounts of  $^{18}\text{O}$  (30 and 37%, respectively) starting with NO.<sup>21</sup> It is not clear how such findings can be reconciled with NO as an obligatory intermediate in the reduction of  $\text{NO}_2^-$ .

The organization of the enzymes of denitrification in Gram-negative bacteria, as determined by cell fractionation, antibody labeling, and electron microscopy studies,<sup>22,23</sup> is shown in Figure 3. As can be seen, the first enzyme, nitrate reductase (NaR),

resides in the cytoplasmic membrane with its active site accessed from the cytoplasmic side, necessitating transport of nitrate across both the periplasmic and the cytoplasmic membranes. The product nitrite is transported back into the periplasmic space, where it is reduced by the nitrite reductase (NiR). Most NiRs appear to be soluble enzymes, although there have been reports of preparations in which the activity was associated with membrane fractions. The nitric oxide reductase (NoR) is localized in the cytoplasmic membrane and releases its product N<sub>2</sub>O back into the periplasmic space, where the soluble enzyme nitrous oxide reductase (NoS) converts it to N<sub>2</sub>.

The first step in denitrification is carried out by the dissimilatory nitrate reductases, which appear to be fairly typical molybdenum oxotransfer enzymes, although their membrane-bound nature has made it difficult to obtain pure homogeneous preparations for detailed physical or mechanistic studies. All preparations appear to contain at least two types of subunit ( $\alpha$ , 104–150 kDa;  $\beta$ , 52–63 kDa) together with molybdenum, both heme and non-heme iron, and acid-labile sulfur.<sup>17</sup> The enzymatic reaction is

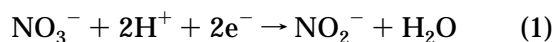

which at least on the surface appears to be a fairly typical molybdenum-catalyzed oxygen atom transfer reaction.<sup>24</sup>

The final step in the denitrification process is carried out by the soluble enzyme nitrous oxide reductase, which has been isolated from a number of sources and is unusual in a number of ways. In most cases, it is a homodimer of ca. 74 kDa subunits with 4 Cu/subunit, but the enzyme is atypically bright purple or pink as isolated, depending on conditions, and becomes the typical blue color expected for copper proteins only after (irreversible) reduction with dithionite.<sup>25</sup> A variety of spectroscopic studies strongly suggest that the enzyme contains at least one mixed-valent, thiolate-bridged Cu(I)–Cu(II) unit that is similar to the binuclear copper center in cytochrome *c* oxidase.<sup>26,27</sup> The reaction catalyzed by the enzyme is deceptively simple

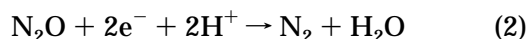

but no mechanistic studies have been reported.

Consequently, this paper will focus on the available structural and mechanistic information concerning the microbial enzymes that carry out the dissimilatory reduction of nitrite and nitric oxide. Crystal structures of two different types of nitrite reductase are now available, as is a wealth of spectroscopic and mechanistic data. As a result, the mechanism of the nitrite reductases is the best understood among the enzymes of denitrification. Although no firm structural data are yet available for a nitric oxide reductase, mechanistic studies are relatively well-advanced, and it is possible to at least engage in intelligent speculation.

## II. Fundamental Considerations

Before we turn to a discussion of the structures and reactions of the nitrite and nitric oxide reductases,

**Table 1. Relevant Reduction Potentials<sup>a</sup>**

reaction	<i>E</i> ' (V)
$\text{NO}_3^- + 2\text{e}^- + \text{H}_2\text{O} \rightleftharpoons \text{NO}_2^- + 2\text{OH}^-$	+0.42
$2\text{NO}_2^- + 4\text{e}^- + 3\text{H}_2\text{O} \rightleftharpoons \text{N}_2\text{O} + 6\text{OH}^-$	+0.77
$\text{NO}_2^- + \text{e}^- + \text{H}_2\text{O} \rightleftharpoons \text{NO} + 2\text{OH}^-$	+0.37
$2\text{NO} + 2\text{e}^- + \text{H}^+ \rightleftharpoons \text{N}_2\text{O} + \text{OH}^-$	+1.18
$\text{N}_2\text{O} + 2\text{e}^- + 2\text{H}^+ \rightleftharpoons \text{N}_2 + \text{H}_2\text{O}$	+1.77
dehydroascorbate + 2e <sup>-</sup> + 2H <sup>+</sup> ⇌ ascorbate	+0.06
fumarate + 2e <sup>-</sup> + 2H <sup>+</sup> ⇌ succinate	+0.03
P – Fe <sup>2+</sup> – NO <sup>+</sup> + e <sup>-</sup> ⇌ P – Fe <sup>2+</sup> – NO <sup>0</sup>	+0.39 to –0.02
P – Fe <sup>2+</sup> – NO <sup>0</sup> + e <sup>-</sup> ⇌ P – Fe <sup>2+</sup> – NO <sup>-</sup>	–0.86

<sup>a</sup> P denotes dianionic porphyrin ligand.

it is perhaps useful to examine some of the basic limitations on the enzymes imposed by the chemical properties of their substrates and products. The nitrogen–oxide species that are sufficiently stable in aqueous solution to act as intermediates in denitrification are listed in Table 1, along with their standard reduction potentials at pH 7. The important point to note is that all of the species listed have quite positive reduction potentials, such that their reduction is likely to be rather exergonic under physiological conditions, albeit somewhat less so than the reduction of O<sub>2</sub> to water. In other words, reduction of nitrate, nitrite, nitric oxide, and nitrous oxide by physiologically relevant electron donors such as succinate provides a sufficiently strong driving force to power the electron transport-coupled oxidative phosphorylation machinery in bacteria. As we shall see subsequently, the data in Table 1 also place important restrictions upon the nature of the intermediates that can plausibly be postulated to occur in the enzymatic reactions as well as on the mechanisms of those reactions.<sup>28</sup>

The second important point concerns those simple nitrogen–oxide species that are not listed in Table 1 because they are not sufficiently stable in solution to allow measurement of standard reduction potentials. These species include trioxodinitrate (oxyhyponitrite), N<sub>2</sub>O<sub>3</sub><sup>2-</sup>; *cis*- or *trans*-hyponitrite, N<sub>2</sub>O<sub>2</sub><sup>2-</sup>; and nitroxyl, HNO. Oxyhyponitrite and both *cis*- and *trans*-hyponitrite are known to exist either as simple salts or as ligands in metal complexes, while HNO has been characterized in the gas phase.<sup>29</sup> All of the above species have been invoked as intermediates in the exceedingly complex reductive solution chemistry of nitrite and related species, but to date there is no compelling evidence for their occurrence as intermediates in the enzymatic reactions.<sup>30,31</sup> Nonetheless, their possible existence must be kept in mind as one considers the extensive and often controversial data available in the literature regarding the mechanism of nitrite and nitric oxide reduction by the enzymes of denitrification.

## III. Dissimilatory Nitrite Reductases

Two distinct types of NiR are known: those containing heme *cd*<sub>1</sub> chromophores and those containing copper. Organisms containing the former appear to be more abundant in nature, although organisms containing the latter occupy a wider range of ecological niches and exhibit more physiological diversity.<sup>32</sup> There is no correlation between the type of enzyme present and the genus/species of the organism, and

no organism has yet been identified that contains both types of NiR. The basic reaction catalyzed by both types of enzyme appears to be the same (but *vide infra*):

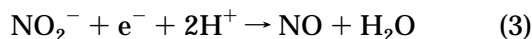

Insights into the mechanism of reduction of nitrite by either class of enzyme have been limited by difficulties in performing classical enzymological studies. A major problem has been the fact that the product NO is a potent inhibitor of nitrite reduction.<sup>33,34</sup> As a result, plots of NO production vs time are nonlinear, and reliable initial velocity studies have not yet been reported. Consequently, even the order of binding of substrates is not known for either class of enzyme (i.e., does nitrite bind to the oxidized enzyme followed by electron transfer from the physiological electron donor, does productive binding of nitrite require prior reduction of the enzyme, or is the order of nitrite binding and enzyme reduction random?). Nonetheless, results from other techniques, most notably spectroscopic measurements and isotope labeling studies, have resulted in a considerable amount of information that gives a reasonable picture of how these enzymes operate.

### A. Heme *cd*<sub>1</sub>-Containing Nitrite Reductases

Nitrite reductases containing hemes *c* and *d*<sub>1</sub> have been isolated from a large number of bacteria, approximately two-thirds of the denitrifying species examined to date. Common source organisms include *Pseudomonas aeruginosa*, *Thiobacillus denitrificans*, *Ps. stutzeri*, *Ps. halodenitrificans*, *Alcaligenes faecalis*, and *Paracoccus denitrificans*.<sup>17</sup> At least one species of *Al. faecalis* is, however, known to produce a copper-containing nitrite reductase: *Al. faecalis* S-6.<sup>35</sup> This fact demonstrates vividly that there is no clear correlation between microbial taxonomy and the type of dissimilatory nitrite reductase present in an organism. The enzymes typically consist of two identical subunits of molecular mass of 60 kDa, each containing one heme *c* prosthetic group covalently linked to the polypeptide chain and one heme *d*<sub>1</sub> moiety noncovalently associated with the protein. Heme *c* binding ligands<sup>36–38</sup> are located near the N-terminus of the protein. Comparison of the amino acid sequences of the NiRs from *Ps. aeruginosa* and *Ps. stutzeri* strain Zobell reveals 56.4% identity,<sup>36</sup> while the *Ps. stutzeri* JM300 sequence exhibits 67% and 88% homology, respectively, to these enzymes.<sup>38</sup> The high degree of sequence homology suggests a common structure and, presumably, mechanism for the enzymes in this class. Not surprisingly, antibodies raised against the NiR from *Ps. aeruginosa* cross-react strongly with those from *Ps. fluorescens* and *Alcaligenes* strains that are commonly found in natural environments.<sup>32</sup> The available evidence thus is consistent with a single common structure for all heme *cd*<sub>1</sub> NiRs.

The presence of heme *d*<sub>1</sub> is unique to denitrifiers with heme *cd*<sub>1</sub> nitrite reductases. Based on spectroscopic studies, Chang proposed a porphyrindione (dioxoisobacteriochlorin) structure (Figure 4) for the green chromophore.<sup>39</sup> Reconstitution of an apoen-

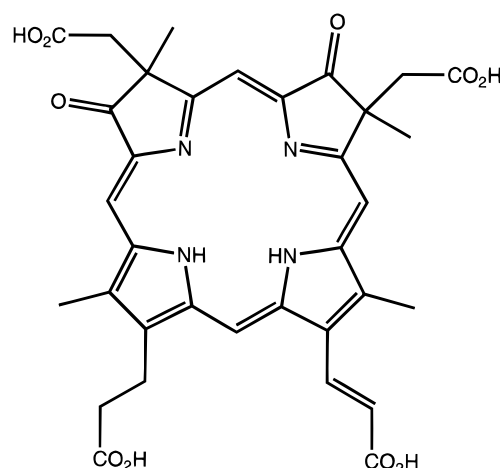
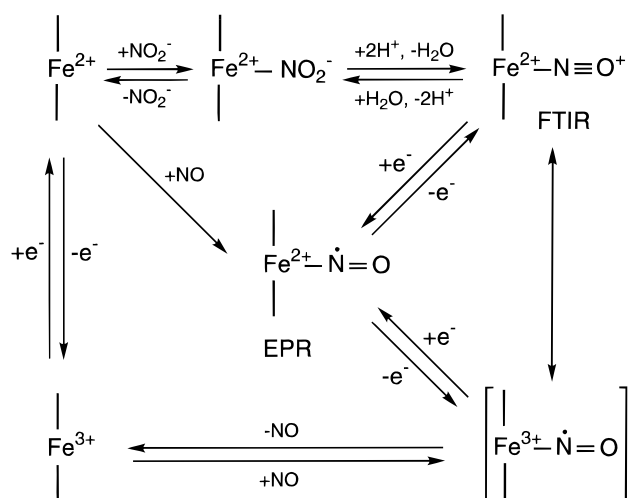

**Figure 4.** Structure of heme *d*<sub>1</sub>.

zyme lacking heme *d*<sub>1</sub> with synthetic heme *d*<sub>1</sub> restored ca. 80% of the enzymatic activity,<sup>40</sup> indicating that the proposed structure is correct and demonstrating that this novel chromophore plays a key but as yet unelucidated role in the conversion of nitrite to NO.

A wide variety of spectroscopic and ligand-binding studies have been carried out on various examples of the heme *cd*<sub>1</sub> NiRs.<sup>41–49</sup> Many date from the days when the enzyme was referred to as “bacterial cytochrome oxidase”, because of its ability to reduce O<sub>2</sub> to water (albeit much more slowly than mammalian cytochrome *c* oxidase) and the presence of four electron acceptor groups per dimer. These studies were aimed at exploring the relationship between the bacterial and mammalian cytochrome oxidases. The analogy with mammalian cytochrome *c* oxidase is now recognized to be weak, and the physiological role of the enzyme in nitrite reduction is generally accepted. Nonetheless, these spectroscopic studies revealed some important points. First, the resting oxidized enzyme contains both a low-spin ferric heme (assigned to the *c* heme) and a mixture of a low- and high-spin ferric heme, both of which are assigned to the heme *d*<sub>1</sub>. Second, the high-spin heme is converted to a low-spin form by a variety of added ligands, such as cyanide. Third, in the reduced enzyme, the heme *d*<sub>1</sub> readily binds  $\pi$ -acid ligands such as CO and NO. In addition, at pH  $\leq$  6 the heme *c* also binds NO. The ferrous heme–NO complexes are analogous electronically to such well-studied species as nitrosylhemoglobin; they have an  $S = 1/2$  ground state and are readily detected by EPR. Because they can also be generated by reaction of the reduced enzyme with nitrite, they have been postulated to be possible intermediates in the reduction of nitrite to NO.<sup>46,47,50</sup>

The kinetics of nitrite reduction by the heme *cd*<sub>1</sub> NiR have been studied by stopped-flow and rapid-freeze EPR spectroscopy.<sup>50</sup> The first step in the reaction is reported to involve binding and dehydration of nitrite and electron transfer from reduced *d*<sub>1</sub> to nitrite, resulting in the formation of a heme *d*<sub>1</sub> Fe<sup>3+</sup>–NO species. This step is very fast, being lost in the mixing time of the instrument. In the second step, an electron is transferred from the heme *c* to heme *d*<sub>1</sub> with a rate constant of 1 s<sup>-1</sup> to form the



**Figure 5.** Proposed mechanism for reduction of nitrite by the heme  $cd_1$ -containing nitrite reductases.

paramagnetic heme  $d_1$   $Fe^{2+}$ -NO complex. When heme  $d_1$  is NO-bound, the rate at which heme  $c$  can accept electrons from ascorbate is remarkably increased as compared to the oxidized enzyme; this electron transfer results in the formation of a  $c^{2+}d_1^{2+}$ -NO species, which can be detected by EPR. The binding of NO to the reduced heme  $d_1$  is very tight, as expected.<sup>51</sup>

As a result of studies by several groups, the mechanism of action of the heme  $cd_1$  NiRs is reasonably well understood and is shown in Figure 5. A variety of work, including elegant isotope exchange and trapping studies from Hollocher's group,<sup>20</sup> has established the existence of an electrophilic nitrosyl intermediate derived from nitrite, which is capable of undergoing nucleophilic attack by nucleophiles such as water, azide, and hydroxylamine. Reaction with water to give bound nitrite is simply the reverse of the initial dehydration reaction and results in the exchange of  $^{18}O$  from  $H_2^{18}O$  into the product NO. Use of  $^{15}NO_2^-$  has allowed the nitrosyl intermediate to be trapped with  $^{14}N_3^-$  or  $C_6H_5^{14}NH_2$  to give  $^{14,15}N_2O$ , which can be detected by mass spectrometry. This electrophilic nitrosyl species is the key intermediate in the mechanism shown in Figure 5. It can be formulated as either a ferrous heme  $d_1$ -NO<sup>+</sup> complex or as a ferric heme  $d_1$ -NO complex. In either case, it is one electron more oxidized than the paramagnetic ferrous heme-NO complex found in nitrosylmyoglobin or nitrosylhemoglobin.<sup>52</sup> By analogy to synthetic ferrous heme  $Fe^{2+}$ -NO<sup>+</sup> complexes, which have been generated electrochemically,<sup>53,54</sup> the ferrous heme  $d_1$ -NO<sup>+</sup> species is expected to be quite unstable and to decompose via an internal electron transfer reaction to produce NO and the ferric heme  $d_1$ , as shown at the bottom of Figure 5. Electron transfer from the ferrous heme  $c$  then reduces the heme  $d_1$  back to the ferrous state.

Two important points should be made regarding the ferrous heme  $d_1$ -NO<sup>+</sup> intermediate. First, although it is diamagnetic and hence not detectable by EPR, it has recently been generated by the back reaction of NO with the oxidized enzyme and observed directly by Fourier transform infrared spectroscopy (FTIR), where it gives an N-O stretching

band at ca.  $1910\text{ cm}^{-1}$ <sup>55</sup> (vs  $1925\text{ cm}^{-1}$  for met Hb-NO and  $1615\text{ cm}^{-1}$  for deoxyHb-NO).<sup>56</sup> Second, known heme  $Fe^{2+}$ -NO<sup>+</sup> species are highly reactive,<sup>54</sup> and decompose rapidly to NO and the  $Fe^{3+}$  heme if the NO<sup>+</sup> species is not trapped by a nucleophile or reduced by one electron to the very stable heme  $Fe^{2+}$ -NO species. The latter have been observed spectroscopically many times, especially by EPR, upon treatment of heme  $cd_1$  NiRs with  $NO_2^-$ .<sup>42,46,47,49,50,57-59</sup> It seems unlikely, however, that such a species can be an intermediate in the reduction of nitrite for the following simple reason: the dissociation rate for NO from ferrous heme proteins is extremely slow (half-lives in the absence of light are measured in days),<sup>51</sup> and the kinetic competence of the paramagnetic ferrous heme-NO complex observed upon reaction of the reduced  $cd_1$  NiR with nitrite has never been demonstrated. Instead, the ferrous heme  $d_1$ -NO complex would appear to be a functionally dead enzyme. This is in agreement with the fact that NO functions as a potent inhibitor of its own formation, presumably due to the buildup of the heme  $d_1$   $Fe^{2+}$ -NO species.<sup>33,34</sup> The role of the heme  $c$  would appear to be to accept electrons from the physiological redox partner(s) and to rapidly reduce the ferric heme  $d_1$  back to the ferrous form, ensuring that it is ready to interact with another molecule of substrate. It is known that the enzyme can be reduced by a variety of electron donors, including azurin or pseudoazurin and cytochrome  $c_{551}$ .<sup>60-63</sup>

The recent report of the  $1.55\text{-\AA}$  crystal structure of the oxidized heme  $cd_1$  NiR from *Thiosphaera pantotropha*, a close relative of *P. denitrificans*,<sup>64</sup> raises as many questions as it answers. The enzyme consists of at least 559 amino acids (no DNA or conventional amino acid sequence information is available and the N-terminus is blocked; mass spectrometry suggests the presence of an additional eight amino acids not seen in the X-ray structure). The protein consists of two domains, a smaller one that contains the covalently bound heme  $c$  (residues 1-134) and a larger one that contains the heme  $d_1$  (residues 135-567) (Chart 1a), supporting the general idea of separate electron transfer (heme  $c$ ) and substrate binding (heme  $d_1$ ) sites. Unexpectedly, however, the coordination to the iron of heme  $c$  is atypical, and the presumed substrate binding site in the heme  $d_1$  site is blocked by a coordinated amino acid side chain.

The heme  $c$  domain is largely  $\alpha$ -helical and bears a general structural resemblance to structurally characterized class 1 cytochromes  $c$  (e.g., tuna cytochrome  $c$ ), although the spatial arrangement and connectivity of the helices differ in detail. The protein ligands to the heme  $c$  are two histidine imidazoles (His-17 and His-69), in contrast to the His/Met ligation expected for this class of cytochromes  $c$  and previously postulated to be present in the heme  $c$  of other heme  $cd_1$  NiRs.<sup>37</sup>

The heme  $d_1$  domain consists of an eight-bladed  $\beta$ -propeller structure surrounding the heme  $d_1$ . The heme  $d_1$  also exhibits unusual ligation, in that one axial ligand is a conventional histidine imidazole (His-200) while the sixth ligand is a tyrosine phenoxide provided by Tyr-25 of the heme  $c$  domain

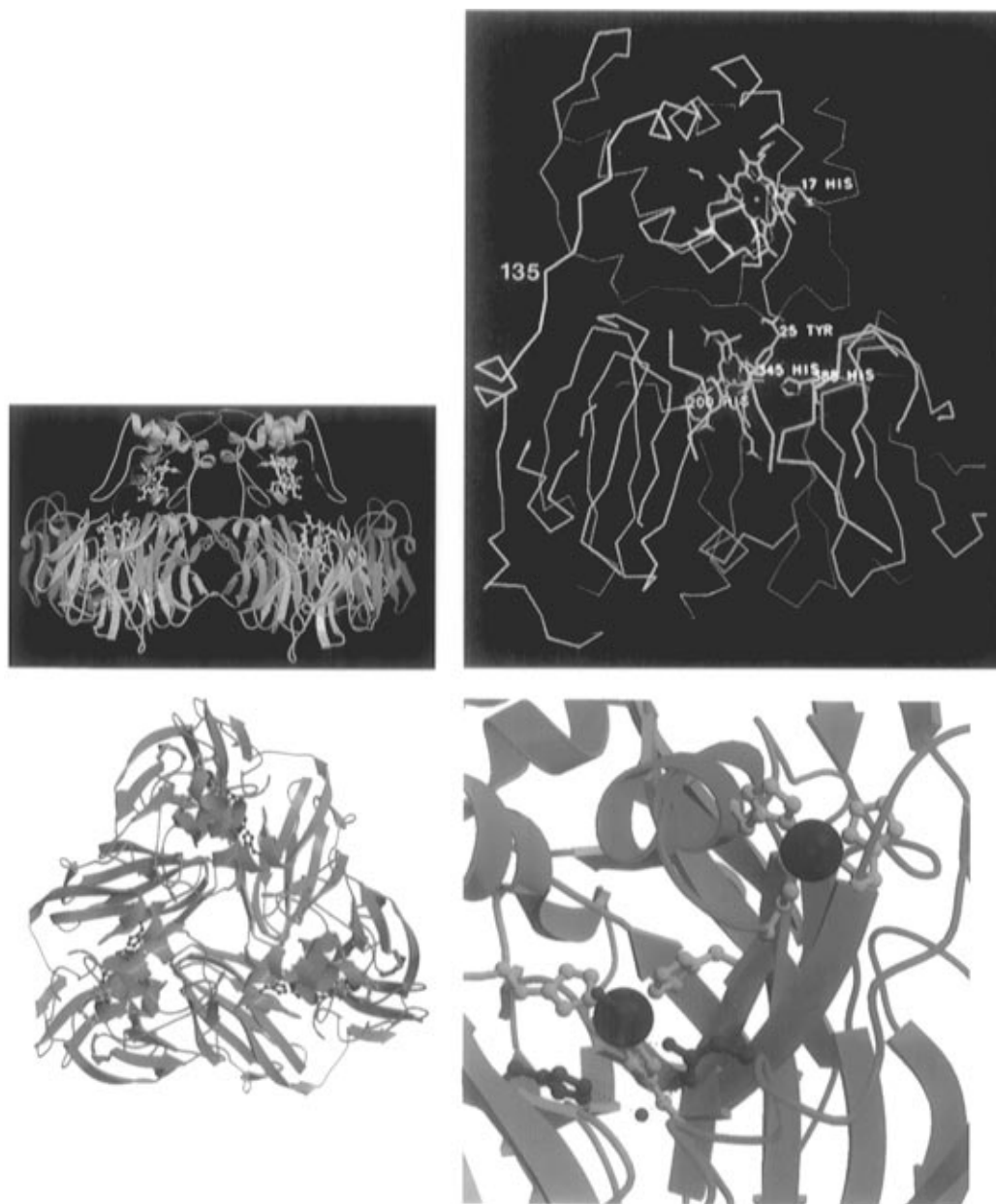
Chart 1<sup>a</sup>

<sup>a</sup> (a, top left) Dimeric two-domain structure of the heme *cd*<sub>1</sub> nitrite reductase from *T. pantosphaera*. (b, top right) Domain structure of the heme *cd*<sub>1</sub> nitrite reductase from *T. pantosphaera*, illustrating the relationship between the two hemes in the monomer—the heme *c* domain is at the top in both panels a and b. (c, bottom left) Overall structure of the trimeric nitrite reductase from *A. cycloclastes*. (d, bottom right) Type 1 and type 2 copper sites in one monomer of *A. cycloclastes* nitrite reductase. Panels a and b are reproduced from ref 64 with permission. Copyright 1995 Cell Press.

(Chart 1b). Tyrosine ligation to hemes is relatively unusual and is well-established only for catalases<sup>65,66</sup> and for hemoglobin mutants such as HbM.<sup>67–69</sup> Its presence normally results in major effects on the reduction potential of the heme:<sup>70</sup> HbM is a pathological mutation because the phenoxide stabilizes the ferric heme to such an extent that methHbM accumulates due to the inability of the erythrocyte to reduce the protein to the deoxy form, and catalases are notoriously difficult to reduce even in the presence of CO. One would therefore expect the presence of a tyrosinate ligand to heme *d*<sub>1</sub> to have notable consequences on the chemistry of the enzyme, and indeed the structural report postulates a role for Tyr-25 in eliminating NO from the enzyme–product complex (Figure 6).

One indication that the situation may be more complex than this is provided by a consideration of amino acid sequence similarities. Although two other heme *cd*<sub>1</sub> NiRs for which sequence data are available do have Tyr residues in or near this position,<sup>37,71,72</sup> it is not strictly conserved. In fact, the available sequences for the enzyme from two strains of *Ps. stutzeri*<sup>38,73</sup> have a major deletion in this region and contain no Tyr residues in the entire heme *c* domain. The possibility that this ligand is absent in solution and coordinates only in the particular conformation studied in the crystal cannot therefore be excluded at this point, especially since no spectroscopic evidence for the presence of the ferric heme-tyrosinate unit has yet been reported. Indeed, it is difficult to reconcile the postulated role of Tyr-25 with the

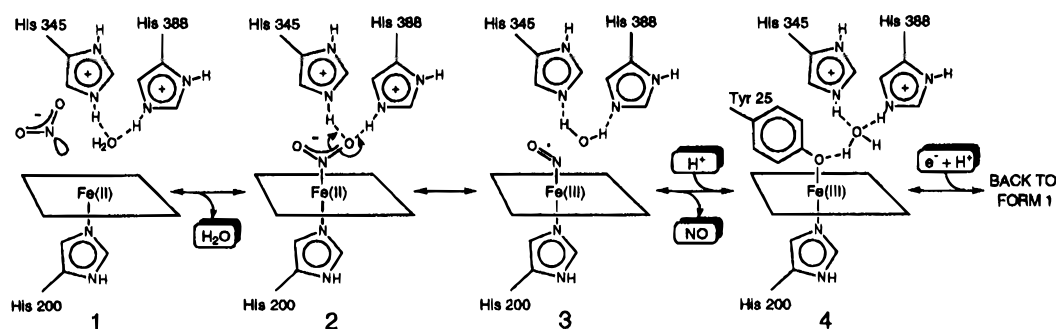

**Figure 6.** Alternative mechanism proposed for reduction of nitrite by the heme  $cd_1$ -containing nitrite reductases based on the X-ray structure of the *T. pantosphaera* enzyme. Reproduced from ref 64 with permission.

**Table 2. A Comparison of Properties Originally Reported for Nitrite Reductases from Different Sources**

source	subunit composition	Cu content	Cu type	specific activity (U/mg)	assay method	ref
<i>Al. faecalis</i>	4 × 30 kDa	4.5	1 and 2	380	ascorbate-PMS	134
<i>A. cycloclastes</i>	3 × 37 kDa	4.5	1 and 2	270	ascorbate-PMS	135
<i>B. halodenitrificans</i>	2 × 40 kDa	1.56	1 and 2	90	ascorbate-PMS	136
<i>Rh. sphaeroides</i>	2 × 39 kDa	2.3	1 and 2	24	methyl viologen	137
<i>Al. xylosoxidans</i>	2 × 37 kDa	1.6	1 only	23	dithionite-benzyl viologen	86
<i>Ps. aureofaciens</i>	2 × 40 kDa	1.9	1 only	1	ascorbate-PMS	85

known properties of ferric heme proteins with tyrosinate ligands.

The two hemes within each monomer of *T. pantotropha* NiR are arranged with an angle of ca. 60° between the heme planes, and an Fe···Fe distance of 20.6 Å. The closest contact between the peripheries of the  $c$  and  $d_1$  hemes is about 11 Å, making the proposed role of heme  $c$  in electron transfer to heme  $d_1$  a reasonable one. The distances between hemes in adjacent subunits are much longer (>40 Å), consistent with the view that each subunit functions independently in nitrite reduction.

Finally, the reaction catalyzed by the enzyme (eq 4) requires two protons to remove one of the oxygen atoms of nitrite as water. The crystal structure<sup>64</sup> shows the presence of two histidine imidazoles (His-345 and His-388) near the position occupied by Tyr-25, which is proposed to dissociate from the heme  $d_1$  to open up a site for nitrite binding and reduction. If the position of these two histidine residues does not change significantly in the active enzyme, they would appear to be ideally located to provide the required protons and/or participate in a highly ordered array of hydrogen-bonded water molecules analogous to that which has been proposed to be important in regulating proton access to the active site in the copper-containing nitrite reductases (*vide infra*).

## B. Copper-Containing Nitrite Reductases

Denitrifiers with copper NiRs comprise one-third of the numerically dominant denitrifiers isolated from soil,<sup>32</sup> and include species from *Pseudomonas*, *Alcaligenes*, *Corynebacterium*, *Bacillus*, *Rhizobium*, *Agrobacterium*, and *Rhodobacter*. Most of the Cu NiRs cross-react with polyclonal antibodies raised against the Cu NiR from *A. cycloclastes*<sup>32</sup> or from *Rh. sphaeroides* forma sp. *denitrificans*,<sup>74</sup> suggesting that they exhibit substantial structural similarity. Originally, many of these enzymes were reported to be dimers or tetramers of identical subunits with molecular weights in the 30–40 kDa range (Table 2). The

publication of a crystal structure of the *A. cycloclastes* NiR in 1991 showing that the enzyme was a trimer with copper sites located between the subunits, however, forced a reassessment of the state of oligomerization of these enzymes.<sup>75</sup> In view of the strong sequence homologies exhibited by members of this class of enzymes (the *Al. faecalis* S-6,<sup>35</sup> *Ps. aureofaciens*,<sup>76</sup> and *Ps. sp. G-179*<sup>77</sup> gene sequences show 81%, 64%, and 78% homology with the sequence of the *A. cycloclastes* protein,<sup>78</sup> respectively), it now seems likely that most if not all Cu NiRs are actually trimeric.

The copper-containing nitrite reductases are similar to the heme  $cd_1$  enzymes in that they also contain two types of metal chromophore. The best characterized example is that from *A. cycloclastes*, for which a 1.9-Å resolution X-ray structure has recently been reported.<sup>79</sup> In addition, a lower resolution (2.6-Å) structure of the *Al. faecalis* S-6 enzyme<sup>35</sup> reveals an essentially identical protein structure and arrangement of the metal ions. Both enzymes consist of  $\alpha_3$  trimers of 37 kDa subunits (Chart 1c), each of which contains two copper atoms in distinct sites (Chart 1d). One is an unusual green variant of the “blue” or type 1 Cu center familiar from plastocyanin or azurin, with one methionine thioether (Met-150), one cysteine thiolate (Cys-136), and two histidine imidazole (His-95 and His-145) ligands. (The numbers refer to the *A. cycloclastes* sequence.) The structure of the type 1 center is, even at high resolution, almost indistinguishable metrically from the Cu sites in plastocyanin and pseudoazurin and reveals no obvious structural basis for the strong band at 458-nm that is responsible for the intense green color. The most significant difference between the green type 1 Cu center of *A. cycloclastes* NiR and the classical type 1 Cu center of poplar plastocyanin is a shorter Cu–SMet bond in the former (2.55 vs 2.82 Å).<sup>79</sup> Resonance Raman spectra clearly indicate, however, that the 458 nm band responsible for the green color possesses substantial CysS→Cu charge transfer char-

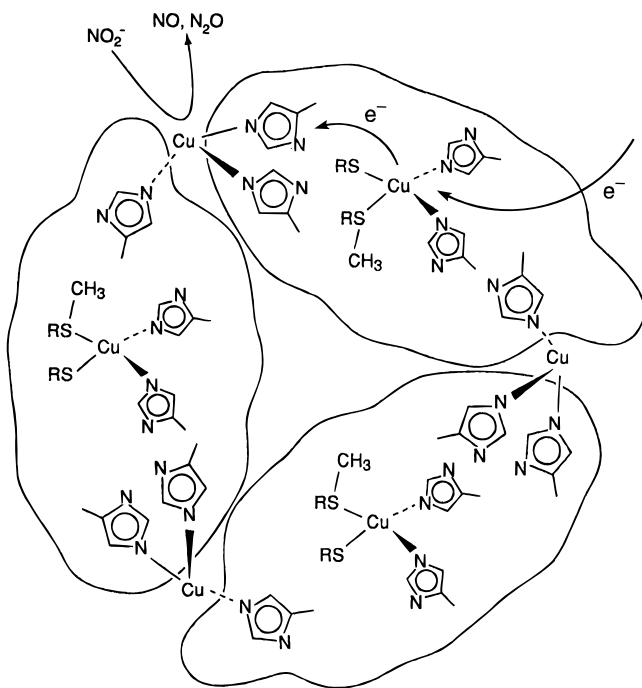

**Figure 7.** Cartoon showing the essential structure and arrangement of the copper centers in the Cu-containing nitrite reductase from *A. cycloclastes*.

acter, suggesting a substantially different description of the bonding in the green type 1 centers than in the well-studied blue type 1 copper centers.<sup>80</sup> The other copper atom, a "non-blue" or type 2 Cu, is coordinated in a roughly tetrahedral fashion by three histidine imidazoles (His-100 and His-135 from the same subunit that ligates the type 1 Cu and His-306 from an adjacent subunit) and a molecule of water. The two copper atoms are thus linked by a pair of amino acids that are adjacent to one another in the polypeptide chain (His-135 and Cys-136), but in an extended conformation. As a result, the Cu...Cu distance is 12.5 Å. A cartoon illustrating the essential points of the structure is shown in Figure 7. The overall structure of the protein and the arrangement of the Cu atoms in the structure is very similar to that observed in the structure of ascorbate oxidase, where the type 2 Cu is part of a trinuclear center lying at the subunit interface.<sup>81</sup>

Both crystallographic studies of nitrite binding to the oxidized *A. cycloclastes* enzyme<sup>82</sup> and studies of type 2 Cu-depleted enzyme,<sup>83</sup> where a linear correlation between type 2 Cu content and specific activity was observed, have shown that the type 2 Cu center is the site at which  $\text{NO}_2^-$  binds and is reduced, analogous to the heme  $d_1$  center in the heme  $cd_1$  enzymes. The role of the type 1 Cu is thus presumably that of an electron transfer center, analogous to the role of the heme  $c$  in the heme  $cd_1$  enzymes. In support of this model, intramolecular electron transfer from the type 1 to the type 2 Cu sites has been observed in pulse radiolysis studies.<sup>84</sup>

It has been reported that the active site of Cu NiRs is the type 1 copper, since only type 1 copper was detected in the Cu NiRs isolated from *Ps. aureofaciens*<sup>85</sup> and *Al. xylooxidans*,<sup>86</sup> and the type 1 site was found to form a nitrosyl complex upon addition of NO.<sup>87</sup> This would imply the existence of unprec-

edented reactivity at a blue Cu center. The following points, however, strongly suggest that the type 2 copper site constitutes the active site of the *A. cycloclastes* enzyme at least. First, nitrite binds to the type 2 copper site, not to the type 1 copper. This is observed in the X-ray structure of the enzyme complexed to  $\text{NO}_2^-$ <sup>79</sup> and in the EPR spectrum of the oxidized enzyme treated with nitrite.<sup>88</sup> Second, the type 2 Cu can be removed from the enzyme, resulting in essentially no activity. The reconstituted enzyme shows a linear correlation between type 2 Cu content and enzymatic activity, whether measured by standard assay methods<sup>83</sup> or electrochemically.<sup>89</sup> Thus, it is now generally agreed that the type 2 Cu center in *A. cycloclastes* NiR is the site at which nitrite is reduced and that the type 1 Cu is the site through which electrons enter the enzyme from physiological electron donors such as pseudoazurin.<sup>90</sup> The previous discrepancies were apparently due to preparations that were largely depleted in the type 2 copper center.

Although a wide variety of copper contents, colors, and quaternary structures has been reported for Cu NiRs (cf. Table 2), it seems likely that most, if not all, of the enzymes have structures and optimal copper contents similar to that of the *A. cycloclastes* enzyme. This assertion is based on several lines of evidence. The *Ps. aureofaciens* NiR, previously reported to contain only a single type 1 Cu per monomer,<sup>85</sup> exhibits a high degree of sequence homology to the *A. cycloclastes* NiR,<sup>76</sup> in particular, all of the ligands to the type 2 Cu are conserved. More recent studies of the *Al. xylooxidans* NiR, also originally reported to contain only type 1 Cu, demonstrate the presence of two Cu per monomer in reconstituted samples with optimal activity,<sup>91</sup> and binding of nitrite to the type 2 Cu in this enzyme has been demonstrated by EPR and ENDOR spectrometry<sup>92</sup> and EXAFS spectroscopy.<sup>93</sup> Finally, the extensive immunological cross-reactivity observed with antibodies to the *A. cycloclastes* enzyme<sup>32</sup> and NiRs from other sources strongly suggests the existence of only a single basic protein structure that utilizes copper for reduction of nitrite. There are, however, a number of unanswered questions regarding the biodiversity of copper-containing nitrite reductases, for example, why the *Ps. aureofaciens* and *Al. xylooxidans* enzymes are blue rather than green.<sup>138</sup>

A mechanism similar to that observed with the heme  $cd_1$  NiR has been proposed for the Cu NiRs<sup>94</sup> (Figure 8, lower half). In this mechanism, nitrite displaces the water bound to the type 2 Cu site to generate a cuprous-nitrite complex. This is drawn in Figure 8 as N-bound, even though the crystal structure of the oxidized enzyme shows the nitrite to be coordinated asymmetrically through the two oxygen atoms. The available structural data on synthetic copper-nitrite complexes<sup>95</sup> suggest that O-coordination is favored for Cu(II),<sup>96</sup> while the only known Cu(I)-nitrite complex is N-bound.<sup>97,98</sup> Since it is not yet known whether nitrite binding to copper occurs prior to or subsequent to reduction of the type 2 copper center, both possibilities must be kept in mind, and in fact an equilibrium between the two forms is plausible. The N-bound form seems most likely to be suited to further reaction, in that it allows



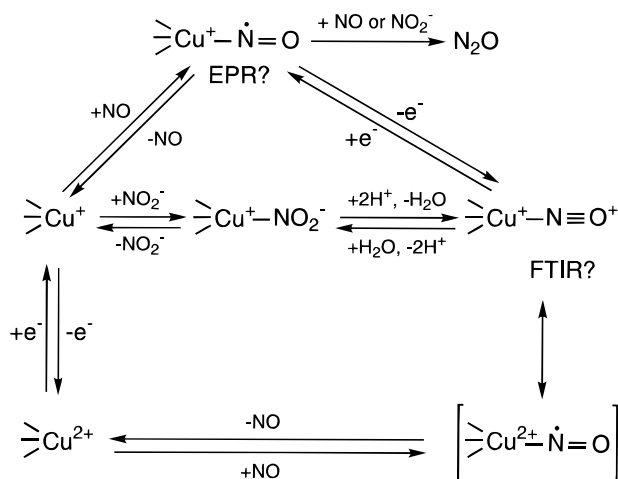

**Figure 8.** Proposed mechanism for reduction of nitrite to nitric oxide (bottom) or nitrous oxide (top) by the Cu-containing nitrite reductases.

generation of an N-bound NO derivative by protonation of one of the more basic uncoordinated oxygen atoms followed by dehydration to give a cuprous- $\text{NO}^+$  species. Such a species is analogous to the ferrous heme- $\text{NO}^+$  species that is well-characterized for the heme  $cd_1$  NiRs. (Protonation and dehydration of O-bound nitrite to give a transient  $\text{Cu}^+-\text{ON}^+$  species has been suggested,<sup>79</sup> but O-coordinated nitrosonium is without precedent.) It has been suggested that binding of nitrite to copper displaces the coordinated water as hydroxide, leaving a proton on the nearby Asp-98 carboxylate side chain.<sup>79</sup> In addition, the imidazole side chain of His-255 and an ordered water bridging between His-255 and Asp-98 are potential sources of the required protons. The  $\text{Cu}^+-\text{NO}^+$  unit would then decompose to the product NO and Cu(II) via an internal electron transfer reaction analogous to that proposed for the heme  $cd_1$  enzymes. The chemistry proposed for the enzyme is supported by the recent finding that protonation of the synthetic  $\text{Cu}(\text{I})-\text{NO}_2^-$  compounds results in smooth conversion of nitrite to NO.<sup>98,99</sup>

The results of site-directed mutagenesis studies on the *Al. faecalis* NiR are consistent with the roles of the two types of copper center outlined above. Thus, replacement of a type 2 Cu ligand, His-135, by Lys resulted in the formation of an altered type 2 site and an enzymatically inactive protein, even though the type 1 Cu site was unperturbed.<sup>35</sup> Conversely, replacement of the type 1 Cu ligand Met-150 by Glu resulted in a protein that bound  $\text{Zn}^{2+}$  in place of Cu in this site, but which contained an unperturbed type 2 center.<sup>100</sup> This enzyme was catalytically almost inactive ( $\approx 10^{-3}$  vs wild type) in nitrite reduction with the physiological electron donor, pseudoazurin. In contrast, the non-physiological electron donor methylviologen was apparently able to "short-circuit" the normal electron transfer pathway and reduce the type 2 Cu directly, resulting in a nitrite reductase activity of  $\approx 5\%$  that of the wild type enzyme.<sup>100</sup>

A variety of evidence, however, suggests that there may be significant differences between the heme and copper enzymes. First, no direct evidence for a  $\text{Cu}^+-\text{NO}^+$  species has been obtained via  $\text{H}_2^{18}\text{O}$  exchange or trapping experiments with the purified enzyme,

only for cell-free extracts where the anomalous properties of the NO reductase (vide infra) might well be responsible.<sup>94</sup> Second, unlike the heme  $cd_1$  enzymes, the Cu NiRs produce a significant amount of  $\text{N}_2\text{O}$  from  $\text{NO}_2^-$ , but only after substantial levels of NO have built up.<sup>101</sup> Third, reaction of  $^{15}\text{NO}_2^-$  with the enzyme in the presence of  $^{14}\text{NO}$  produced large amounts of  $^{14,15}\text{N}_2\text{O}$ .<sup>101</sup> These results suggest that a labile  $\text{Cu}-\text{NO}$  species accumulates and is capable of reacting either with  $\text{NO}_2^-$  or with NO derived from  $\text{NO}_2^-$  to produce  $\text{N}_2\text{O}$  (Figure 8, upper half). The net charge on such a species could conceivably range from +1 to +3, depending on the oxidation state of copper and NO, but a  $\text{Cu}^+-\text{NO}^+$  formulation seems most probable. The available data do not permit a distinction to be made regarding the chemical form in which the second nitrogen atom enters the product  $\text{N}_2\text{O}$ . It is, however, worth noting that potentially related chemistry has been demonstrated for synthetic Cu complexes. Reaction of Cu(I) complexes with suitably functionalized hydrotris(pyrazolyl)borate ligands and NO has been demonstrated to result in a disproportionation reaction that produces  $\text{N}_2\text{O}$  and the corresponding Cu(II)-nitrite complex.<sup>102</sup> Although it is not yet clear that  $\text{N}_2\text{O}$  production by the Cu NiRs is significant under physiological conditions, in which NO is normally rapidly removed, it may be important under conditions where NO reductase function is impaired (by, e.g., high levels of NO, see below).

#### IV. Nitric Oxide Reductases

Two types of nitric oxide reductase are now known: the membrane-bound enzyme found in denitrifying bacteria and a soluble enzyme that appears to be responsible for reduction of NO by certain fungi that carry out a process that bears significant similarities to denitrification. As will become clear, the two enzymes appear to operate via very different mechanisms.

##### A. Bacterial Nitric Oxide Reductases

Nitric oxide reductase (NoR) was the last of the enzymes of denitrification to be obtained in pure form. As indicated in Figure 3, the enzyme appears to be an integral membrane protein, and a variety of detergents have been used to solubilize it. Homogeneous preparations have been obtained from two sources to date (*Ps. stutzeri* Zobell<sup>103,104</sup> and *P. denitrificans*),<sup>105,106</sup> as has a highly purified but not homogeneous preparation from *A. cycloclastes*.<sup>107</sup> All appear to consist of a heterodimer with subunits of ca. 53 and 17 kDa, containing a cytochrome *b* and a cytochrome *c*, respectively, which in the oxidized enzyme give rise to EPR spectra typical of a ca. 1:1 mixture of low- and high-spin hemes, respectively.<sup>104</sup> In addition, significant quantities of non-heme iron (3–6/mol) are reported to be present in at least some preparations.<sup>103–106</sup> A feature that has complicated interpretation of mechanistic studies is the fact that there appears to be a strong coupling between the nitrite reductase and nitric oxide reductase activities at all levels: transcriptional, translational, and even mechanistic.<sup>1,19,108,109</sup> These results suggest that the two enzymes may function as a multienzyme complex



anchored electron transfer proteins with similar topologies, with in one case a heme *c* and in the other case a binuclear Cu<sub>A</sub> center as the redox active chromophore. More significantly, there exists significant sequence homology between the NorB protein and subunit I of cytochrome oxidase. Both are postulated to contain a total of 12 membrane-spanning helices, and in particular the six histidine residues that are known to provide ligands to hemes *a* and *a*<sub>3</sub> and Cu<sub>a3</sub> are conserved. The analogy to a more primitive cytochrome oxidase, FixN or cytochrome *cbb*<sub>3</sub>, is even stronger, in that the latter possesses a subunit II that contains a cytochrome *c* rather than a binuclear Cu<sub>A</sub> center. Based on these analogies, it has been suggested that the NoR actually contains *two* cytochromes of type *b* in the larger subunit, one of which may be lost during purification.<sup>117,118</sup> In addition, the conserved His residues strongly suggest the presence of a non-heme metal, possibly one of the non-heme iron atoms rather than copper, located in a binuclear center similar to the heme *a*<sub>3</sub>-Cu<sub>a3</sub> unit of cytochrome oxidase. Carrying the analogy to completion would imply that NO is reduced at this binuclear heme-nonheme center, in analogy to the reduction of O<sub>2</sub> by cytochrome *c* oxidase. Synthetic compounds with structures similar to that suggested above have recently been reported,<sup>119</sup> and their reactivity with NO is likely to prove interesting in this regard.

Any of the mechanistic possibilities discussed above is potentially consistent with both the <sup>18</sup>O exchange data and the observed inhibition by NO of its own reduction. All that is required for the former is an iron-nitrosyl intermediate (Fe-NO) that is in equilibrium with the one-electron oxidized species (Fe-NO<sup>+</sup>), presumably via internal electron transfer to one of the other heme or nonheme centers present. If the oxidized species is relatively electrophilic and long-lived, then attack by water to produce a transient bound nitrite is chemically reasonable. Similarly, the inhibition of NO reduction by NO is consistent with NO binding with lower affinity to a site remote from the catalytic site, presumably interrupting internal electron transfer by tying up one of the iron sites (a heme *c*?) as the low-spin ferrous-NO complex.

## B. Fungal Nitric Oxide Reductases

It has long been known that fungi were capable of converting small but significant amounts of NO<sub>3</sub><sup>-</sup> or NO<sub>2</sub><sup>-</sup> into N<sub>2</sub>O (typical yields <15%).<sup>11</sup> Recently, however, it has become clear that certain strains of fungi, notably *Fusarium* sp., are capable of *quantitative* conversion of NO<sub>3</sub><sup>-</sup> and NO<sub>2</sub><sup>-</sup> to N<sub>2</sub>O,<sup>16</sup> in a process termed fungal denitrification. It remains unclear whether this represents true respiratory denitrification, since neither extended anaerobic growth on either substrate nor coupling of N-oxide reduction to energy generation has been reported. Instead, the dissimilatory reduction of NO<sub>2</sub><sup>-</sup> and NO<sub>2</sub><sup>-</sup> may represent some sort of detoxification process, but definitive evidence is lacking. Regardless of its physiological role, the process is capable of producing large amounts of N<sub>2</sub>O and is likely to be important in certain ecological niches (e.g., forest soils).<sup>120</sup>

Fungal denitrification poses an intriguing biochemical puzzle for several reasons. First, most fungi examined produce N<sub>2</sub>O as the only gaseous product, with no evidence for N<sub>2</sub> production.<sup>16</sup> Thus, fungi apparently do not contain N<sub>2</sub>O reductase. Second, these fungi are capable of a process termed "codenitrification", in which <sup>15</sup>NO<sub>2</sub><sup>-</sup> is reduced to (<sup>14</sup>N,<sup>15</sup>N)<sub>2</sub>O in the presence of <sup>14</sup>NH<sub>4</sub><sup>+</sup>, <sup>14</sup>N<sub>3</sub><sup>-</sup>, or hydroxamates.<sup>121</sup> This is very reminiscent of the nitrosation reactions observed with the heme *cd*<sub>1</sub> nitrite reductases<sup>20,122</sup> and suggests the presence of an electrophilic oxidized NO intermediate, analogous to that seen with the bacterial NoRs. Third, the inducible nitrite reductase in at least one such species, *F. oxysporum* MT811, has been shown to be a copper-containing enzyme that appears to be virtually identical to the Cu NiRs from denitrifying bacteria discussed above.<sup>123</sup> It contains two atoms of copper per 42 kDa subunit, is reported to be a dimer in solution, and is blue, with an optical spectrum similar to those of the *Al. xylooxidans* and *Ps. aureofaciens* NiRs. How an analog of a prokaryotic enzyme has come to be present in a eukaryote is an intriguing and unresolved issue. Finally, and most importantly for the purposes of this paper, published work suggests that the fungal enzyme responsible for reduction of NO exhibits novel reactivity. Thus, the active NO reductase in a number of fungal species has been shown to be a cytochrome P450;<sup>124-126</sup> initial reports attributing to it a role in reduction of nitrite rather than NO were in error.

The nitric oxide reductase from *F. oxysporum* MT-811 has been purified<sup>125</sup> and its DNA sequence determined.<sup>127</sup> Both are consistent with its classification as a cytochrome P450, which exhibits high homology to typical bacterial P450s from, for example, *Streptomyces*. How fungi have apparently adapted a system that has evolved for monooxygenase reactions into a catalyst for nitric oxide reduction represents a challenging problem. Although an X-ray structure is not yet available,<sup>128</sup> the reported spectroscopic properties (e.g., optical and EPR) are those of a typical cytochrome P450. Thus, the optical spectrum of the reduced CO complex<sup>129</sup> and the EPR spectra of the oxidized enzyme,<sup>130</sup> both free and complexed to cyanide, and the unstable NO complex of the reduced enzyme<sup>131</sup> are all virtually identical to those of the well-studied P450<sub>cam</sub> from *Ps. putida*; hence, it is referred to as P450<sub>nor</sub>. The redox potential of the enzyme (-307mV) is, however, about 60mV more negative than that of P450<sub>cam</sub>.<sup>130</sup>

Although the spectroscopic properties are unremarkable, the observed reactivity is quite unusual and offers substantial insight into the mechanism by which the enzyme reduces NO. The reaction catalyzed by P450<sub>nor</sub> is shown in

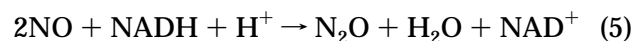

The enzyme is absolutely specific for NADH, showing no activity with NADPH.<sup>132</sup> Direct interaction of NAD(P)H with a heme enzyme in the absence of a flavin center to act as a 2e<sup>-</sup>/1e<sup>-</sup> "transformer" is most unusual. For example, most microbial cytochromes P450 react only indirectly with NAD(P)H, by means of a flavoprotein reductase and an intervening elec-

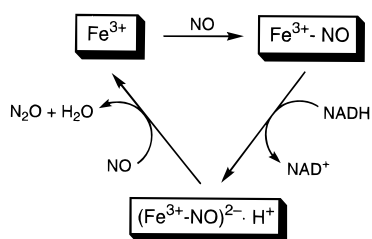

**Figure 12.** Proposed mechanism for reduction of nitric oxide by the fungal P-450 nitric oxide reductase. Adapted from ref 131.

tron transfer protein such as putidaredoxin, with an  $\text{Fe}_2\text{S}_2$  cluster that transfers electrons to the P450 one at a time. That one-electron chemistry is apparently not important in the reaction catalyzed by  $\text{P450}_{\text{nor}}$  is supported by the fact that the reduction of NO is not inhibited by CO,<sup>132</sup> which would be expected to trap any high-spin ferrous intermediates quite efficiently and that the enzyme functions when expressed in *E. coli* in the absence of any other physiological electron donors.<sup>133</sup> Spectroscopic studies show that the oxidized  $\text{P450}_{\text{nor}}$  forms a stable ferric heme–NO complex, which reacts with NADH to give a relatively long-lived transient species that has not yet been identified. The intermediate is formulated only as “ $(\text{Fe}^{3+}\text{–NO})^{2-}\cdot\text{H}^+$ ”,<sup>131</sup> with no suggestion of an actual structure; a plausible structure is suggested below. In the absence of additional NO, decomposition of this intermediate to produce the ferric enzyme and, presumably,  $\text{N}_2\text{O}$  is quite slow ( $k = 0.027 \text{ s}^{-1}$ ), over 4 orders of magnitude too slow for it to be kinetically competent (turnover number  $\approx 1200 \text{ s}^{-1}$ ). Additional NO greatly enhances the rate of breakdown of the intermediate, however, and the authors suggest a mechanism that involves the rapid reaction of a second molecule of NO with the intermediate to produce  $\text{N}_2\text{O}$  (Figure 12).

The mechanism shown in Figure 12 is probably correct in its general features, but it is somewhat unsatisfying in that it sidesteps the normal reactivity of NADH: donation of a hydride. As was discussed in connection with the heme  $cd_1$  nitrite reductases, a ferric heme–NO description such as that shown in Figure 12 is only one possible resonance structure, the other being a ferrous heme– $\text{NO}^+$  complex (cf. Figure 5). Regardless of the precise electronic distribution, virtually all such species known exhibit substantial electrophilic character and, in particular, tend to react readily with nucleophiles. One possibility that has apparently not been explicitly considered is direct hydride transfer from NADH to the ferric heme–NO complex to generate HNO coordinated to the heme (Figure 13). This HNO-containing species would correspond to the long-lived intermediate that reacts rapidly with NO to generate  $\text{N}_2\text{O}$  and regenerate the ferric heme. Examples of coordinated HNO are not particularly common in the organometallic literature, and those that have been characterized have been generated by the protonation of coordinated  $\text{NO}^-$  species with strong acids rather than by attack of hydrides upon electrophilic nitrosyls. Nonetheless, the revised mechanism shown in Figure 13 is attractive in that it utilizes known chemistry of both NADH as a nucleophile and the ferric heme–NO complex as an electrophile.

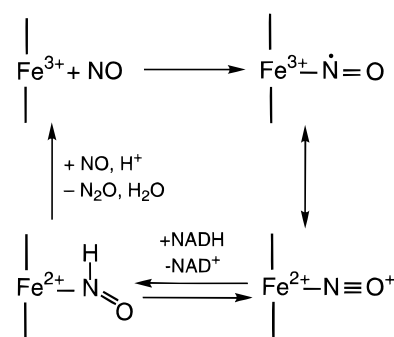

**Figure 13.** Proposed mechanism for reduction of nitric oxide by the fungal nitric oxide reductase with coordinated HNO as an intermediate.

As a final caveat, however, a variant of the mechanism proposed by Caughey et al. for reduction of NO by cytochrome *c* oxidase (Figure 10) would also seem to be consistent with the available data and with the known ability of cytochromes P450 to stabilize highly oxidized intermediates. In this case, the long-lived intermediate in reduction of NO by  $\text{P450}_{\text{nor}}$  would correspond to the high-valent iron–nitride species shown in Figure 10. Since the intermediate is sufficiently stable for spectroscopic characterization, it should be possible to probe its structure with appropriate techniques to determine whether the N–O bond is still intact and, perhaps, whether an H(D) atom is part of the chromophore.

## V. Conclusions

The enzymes discussed above are lovely illustrations of a relatively general phenomenon in biochemistry: the occurrence of multiple, chemically equivalent but apparently evolutionarily unrelated solutions to an important biological problem. In the cases discussed, the problem was how to reduce nitrite or nitric oxide efficiently, but other examples abound in inorganic biochemistry. For example, three unrelated types of reversible oxygen carrier are known (hemoglobin/myoglobin vs hemerythrin vs hemocyanin), as are at least three distinct types of ribonucleotide reductase (containing cobalamin, non-heme iron, or manganese) and two types of catalase (heme iron vs manganese).

In all such cases, comparison of what is known about the various approaches taken by organisms throughout evolution reveals key features of the reaction and important constraints imposed by the chemical nature of the substrates. For example, reduction of nitrite by both the Cu and heme  $cd_1$  NiRs proceeds by initial protonation at oxygen and elimination of one oxygen atom by dehydration. This is certainly not the only conceivable way in which this reaction could be carried out. Thus, molybdoenzymes are in general well-suited to carry out reactions involving abstraction of an oxygen atom, yet no example of a molybdenum-catalyzed reduction of nitrite has (yet) been observed in biochemistry. One might reasonably assume that the product of such a reaction,  $\text{NO}^-$ , is either too high in energy to be a thermodynamically accessible intermediate product or that it is simply too reactive with other molecules for its presence to be tolerated in a cell.

Similarly, the major problem in reduction of NO is formation of the N–N bond of N<sub>2</sub>O under conditions where diffusible, toxic species capable of nitrosation reactions are not generated. Both examples known from bacteria appear to share at least one feature: the presence of an electrophilic species derived from NO on or in equilibrium with the catalytic pathway. Once again, there is no compelling evidence that the conceptually simplest route, one-electron reduction of NO to NO<sup>-</sup> followed by non-enzymatic dimerization and dehydration to N<sub>2</sub>O, is utilized. There must be compelling chemical and/or biochemical reasons for the more complex strategies that have evolved. As these enzymes, especially the bacterial nitric oxide reductases, become better characterized and a wider array of spectroscopic and mechanistic techniques is brought to bear upon them, the chemical basis for the observed biochemical diversity should become apparent.

## VI. Acknowledgments

Research in the author's laboratory was previously supported by grants from USDA-NRICGP (91-37305-6663) and NSF (DMB-8917427, MCB-9307501) and has been a close collaboration with the group of J. M. Tiedje at Michigan State University. I thank him for educating me regarding the importance of considering the bacterial cell as more than the sum of its parts. In addition, I would like to thank E. Adman for helpful criticisms of the manuscript and for providing the color figures used in Chart 1 (c and d), M. van Velzen for critical reading of the manuscript and assistance with the references, and M. Merckx and V. L. Strother for their helpful comments regarding the manuscript.

## Note Added in Proof

A detailed analysis of the differences in electronic structure between the green type 1 Cu center and a "normal" blue type 1 Cu center has appeared: La Croix, L. B.; Shadle, S. E.; Wang, Y.; Averill, B. A.; Hedman, B.; Hodgson, K. O.; Solomon, E. I. *J. Am. Chem. Soc.* **1996**, *118*, 7755–7768.

## VII. References and Notes

- (1) Ye, R. W.; Averill, B. A.; Tiedje, J. M. *Appl. Environ. Microbiol.* **1994**, *60*, 1053–8.
- (2) Berks, B. C.; Ferguson, S. J.; Moir, J. W. B.; Richardson, D. J. *Biochim. Biophys. Acta* **1995**, *1232*, 97–173.
- (3) Hauck, R. D. In *Terrestrial Nitrogen Cycles*; Clark, F. E., Rosswall, T., Eds.; Swedish Natural Resource Council: Stockholm, 1981; Vol. 33, p 558.
- (4) Rasmussen, R. A.; Khalil, M. A. K. *Science* **1986**, *232*, 1623–24.
- (5) Hutchins, H. R. *Appl. Environ. Microbiol.* **1991**, *57*, 2403–07.
- (6) Mellor, R. B.; Ronnenberg, J.; Campbell, W. H.; Diekmann, S. *Nature* **1992**, *355*, 717–9.
- (7) Wang, J. H.; Baltzis, B. C.; Lewandowski, G. A. *Biotechnol. Bioeng.* **1995**, *46*, 159–71.
- (8) Koshland, D. E. J. *Science* **1992**, *258*, 1861.
- (9) Payne, W. J. *Denitrification*; John Wiley & Sons: New York, 1981.
- (10) Knowles, R. *Microbiol. Rev.* **1982**, *46*, 43–70.
- (11) Tiedje, J. M. In *Biology of anaerobic microorganisms*; Zehnder, A. J. B., Ed.; John Wiley & Sons, Inc: New York, 1988; pp 179–243.
- (12) Stouthammer, A. F.; Boogerd, F. C.; van Verseveld, H. W. *Antonie van Leeuwenhoek J. Microbiol. Serol.* **1985**, *48*, 545–53.
- (13) Brittain, T.; Blackmore, R.; Greenwood, C.; Thomson, A. J. *Eur. J. Biochem.* **1992**, *209*, 793–802.
- (14) Liu, M. C.; Bakel, B. W.; Liu, M. Y.; Dao, T. N. *Arch. Biochem. Biophys.* **1988**, *262*, 259–65.
- (15) Crane, B. R.; Siegel, L. M.; Getzoff, E. D. *Science* **1995**, *270*, 59–67.
- (16) Shoun, H.; Kim, D.-H.; Uchiyama, H.; Sugiyama, J. *FEMS Microbiol. Lett.* **1992**, *94*, 277–82.
- (17) Hochstein, L. I.; Tomlinson, G. A. *Annu. Rev. Microbiol.* **1988**, *42*, 231–61.
- (18) Averill, B. A.; Tiedje, J. M. *FEBS Lett.* **1982**, *138*, 8–12.
- (19) Zumft, W. G. *Arch. Microbiol.* **1993**, *160*, 253–64.
- (20) Kim, C. H.; Hollocher, T. C. *J. Biol. Chem.* **1984**, *259*, 2092–9.
- (21) Ye, R. W.; Toro-Suarez, I.; Tiedje, J. M.; Averill, B. A. *J. Biol. Chem.* **1991**, *266*, 12848–51.
- (22) Coyne, M. S.; Arunakumari, A.; Pankratz, H. S.; Tiedje, J. M. *J. Bacteriol.* **1990**, *172*, 2558–62.
- (23) Körner, H.; Mayer, F. *Arch. Microbiol.* **1992**, *157*, 218–22.
- (24) Burgmayer, S. J. N.; Stiefel, E. I. *J. Chem. Educ.* **1985**, *62*, 943–53.
- (25) Antholine, W. E.; Kastrau, D. H. W.; Steffens, G. C. M.; Buse, G.; Zumft, W. G.; Kroneck, P. M. H. *Eur. J. Biochem.* **1993**, *209*, 875–81.
- (26) Andrew, C. R.; Han, J.; de Vries, S.; van der Oost, J.; Averill, B. A.; Loehr, T. M.; Sanders-Loehr, J. *J. Am. Chem. Soc.* **1994**, *116*, 10805–06.
- (27) Kroneck, P. M. H.; Antholine, W. A.; Riestler, J.; Zumft, W. G. *FEBS Lett.* **1989**, *248*, 212–3.
- (28) Stedman, G. *Adv. Inorg. Chem. Radiochem.* **1979**, *22*, 113–65.
- (29) Bonner, F. T.; Hughes, M. N. *Commun. Inorg. Chem.* **1988**, *7*, 215–34.
- (30) Stamler, J. S.; Singel, D. J.; Loscalzo, J. *Science* **1992**, *258*, 1898–902.
- (31) Bonner, F. T.; Hughes, M. N. *Science* **1993**, *260*, 145–6.
- (32) Coyne, M. S.; Arunakumari, A.; Averill, B. A.; Tiedje, J. M. *Appl. Environ. Microbiol.* **1989**, *55*, 2924–31.
- (33) Dhesi, R.; Timkovich, R. *Biochem. Biophys. Res. Commun.* **1984**, *123*, 966–72.
- (34) Payne, W. J.; Riley, P. S.; Cox, C. D., Jr. *J. Bacteriol.* **1971**, *106*, 356–61.
- (35) Kukimoto, M.; Nishiyama, M.; Murphy, M. E. P.; Turley, S.; Adman, E. T.; Horinouchi, S.; Beppu, T. *Biochemistry* **1994**, *33*, 5246–52.
- (36) Jünger, A.; Wakabayashi, S.; Matsubara, H.; Zumft, W. G. *FEBS Lett.* **1991**, *279*, 205–9.
- (37) Silvestrini, M. C.; Galeotti, C. L.; Gervais, M.; Schinia, E.; Barra, D.; Bossa, F.; Brunori, M. *FEBS Lett.* **1989**, *254*, 33–8.
- (38) Smith, G. B.; Tiedje, J. M. *Appl. Environ. Microbiol.* **1992**, *58*, 376–84.
- (39) Chang, C. K. *J. Biol. Chem.* **1985**, *260*, 9520–2.
- (40) Weeg-Aeressens, E.; Wu, W.; Ye, R. W.; Tiedje, J. M.; Chang, C. K. *J. Biol. Chem.* **1991**, *266*, 7496–502.
- (41) Walsh, T. A.; Johnson, M. K.; Thomson, A. J.; Barber, D.; Greenwood, C. *J. Inorg. Biochem.* **1981**, *14*, 1–14.
- (42) Johnson, M. K.; Thomson, A. J.; Walsh, T. A.; Barber, D.; Greenwood, C. *Biochem. J.* **1980**, *189*, 285–94.
- (43) Sutherland, J.; Greenwood, C.; Peterson, J.; Thomson, A. J. *Biochem. J.* **1986**, *233*, 893–8.
- (44) Barber, D.; Parr, S. R.; Greenwood, C. *Biochem. J.* **1978**, *175*, 239–49.
- (45) Parr, S. R.; Wilson, M. T.; Greenwood, C. *Biochem. J.* **1975**, *151*, 51–9.
- (46) Shimada, H.; Orii, Y. *FEBS Lett.* **1975**, *54*, 237–40.
- (47) Muhoberac, B. B.; Wharton, D. C. *J. Biol. Chem.* **1980**, *255*, 8437–42.
- (48) Muhoberac, B. B.; Wharton, D. C. *J. Biol. Chem.* **1983**, *258*, 3019–27.
- (49) Shimada, H.; Orii, Y. *J. Biochem. (Tokyo)* **1978**, *84*, 1553–8.
- (50) Silvestrini, M. C.; Tordi, M. G.; Musci, G.; Brunori, M. *J. Biol. Chem.* **1990**, *265*, 11783–87.
- (51) Traylor, T. G.; Sharma, V. S. *Biochemistry* **1992**, *31*, 2847–9.
- (52) Antonini, E.; Brunori, M. *Hemoglobin and myoglobin in their reactions with ligands*; North-Holland Publishing Co.: Amsterdam, 1971.
- (53) Fujita, E.; Fajer, J. *J. Am. Chem. Soc.* **1983**, *105*, 6743–5.
- (54) Olson, L. W.; Schaeper, D.; Lacon, D.; Kadish, K. M. *J. Am. Chem. Soc.* **1982**, *104*, 2042–4.
- (55) Wang, Y.; Averill, B. A. *J. Am. Chem. Soc.* **1996**, *118*, 3972–3.
- (56) Sampath, V.; Zhao, X.-J.; Caughey, W. S. *Biochem. Biophys. Res. Commun.* **1994**, *198*, 281–7.
- (57) Cox, C. D. J.; Payne, W. J.; DeVertanian, D. V. *Biochim. Biophys. Acta* **1971**, *253*, 290–4.
- (58) LeGall, J.; Payne, W. J.; Morgan, T. V.; DerVartanian, D. *Biochem. Biophys. Res. Commun.* **1979**, *87*, 355–62.
- (59) Liu, M. C.; DerVartanian, D.; Peck, H. D., Jr. *Biochem. Biophys. Res. Commun.* **1980**, *96*, 278–85.
- (60) Dodd, F. E.; Hasnain, S. S.; Hunter, W. N.; Abraham, Z. H. L.; Debenham, M.; Kanzler, H.; Eldridge, M.; Eady, R. R.; Ambler, R. P.; Smith, B. E. *Biochemistry* **1995**, *34*, 10180–6.
- (61) Parr, S. R.; Barber, D.; Greenwood, C.; Brunori, M. *Biochem. J.* **1977**, *167*, 447–55.

- (62) Moir, J. W. B.; Baratta, D.; Richardson, D. J.; Ferguson, S. J. *Eur. J. Biochem.* **1993**, *212*, 377–85.
- (63) Yamanaka, T.; Ota, A.; Okunuki, K. *Biochim. Biophys. Acta* **1961**, *53*, 294–308.
- (64) Fülöp, V.; Moir, J. W. B.; Ferguson, S. J.; Hajdu, J. *Cell* **1995**, *81*, 360–77.
- (65) Reid, T. J., III; Murthy, M. R. N.; Sicignano, A.; Tanaka, N.; Musick, W. D. L.; Rossman, M. G. *Proc. Natl. Acad. Sci. U.S.A.* **1981**, *78*, 4767–71.
- (66) Fito, I.; Rossman, M. G. *J. Mol. Biol.* **1985**, *87*, 21–37.
- (67) Perutz, M. F.; Lehmann, H. *Nature* **1968**, *219*, 902–9.
- (68) Dickerson, R. E.; Geis, I. *Hemoglobin: Structure, Function, Evolution, and Pathology*; Benjamin/Cummings: Menlo Park, CA, 1983.
- (69) Weatherall, D. J.; Clegg, J. B.; Higgs, D. R.; Wood, W. G. In *The Metabolic Basis of Inherited Disease*, 6th ed.; Scriver, C. R., Beaudet, A. L., Sly, W. S., Valle, D., Eds.; McGraw-Hill: 1989; pp 2281–339.
- (70) Cowan, J. A. In *Inorganic Biochemistry. An Introduction*; VCH Publisher, Inc.: New York, 1993; p 265.
- (71) Ohshima, T.; Sugiyama, M.; Uozumi, N.; Iijima, S.; Kobayashi, T. *J. Ferm. Bioeng.* **1993**, *76*, 82–8.
- (72) de Boer, A. P. N.; Reijnders, W. N. M.; Juenen, J. G.; Stouthamer, A. H.; van Spanning, R. J. M. *Antonie van Leeuwenhoek* **1994**, *66*, 111–27.
- (73) Jüngst, A.; Braun, C.; Zumft, W. G. *Mol. Gen. Genet.* **1991**, *225*, 241–8.
- (74) Michalski, W. P.; Nicholas, D. J. D. *Phytochemistry* **1988**, *27*, 2451–6.
- (75) Godden, J. W.; Turley, S.; Teller, D. C.; Adman, E. T.; Liu, M. Y.; Payne, W. J.; LeGall, J. *Science* **1991**, *253*, 438–42.
- (76) Glockner, A. B.; Zumft, W. G. *Arch. Microbiol.* **1993**, *160*, 18–26.
- (77) Ye, R. W.; Fries, M. R.; Bezborodnikov, S. G.; Averill, B. A.; Tiedje, J. M. *Appl. Environ. Microbiol.* **1993**, *59*, 250–4.
- (78) Fenderson, F. F.; Kumar, S.; Adman, E. T.; Liu, M. Y.; Payne, W. J.; LeGall, J. *Biochemistry* **1991**, *30*, 7180–5.
- (79) Adman, E. T.; Godden, J. W.; Turley, S. *J. Biol. Chem.* **1995**, *270*, 27458–74.
- (80) Han, J.; Loehr, T. M.; Lu, Y.; Selverstone-Valentine, J.; Averill, B. A.; Sander-Loehr, J. *J. Am. Chem. Soc.* **1993**, *115*, 4256–63.
- (81) Messerschmidt, A.; Rossi, A.; Ladenstein, R.; Huber, R.; Bolognesi, M.; Gatti, G.; Marchesini, A.; Petruzzelli, R.; Finazzi-Agrò, A. *J. Mol. Biol.* **1989**, *206*, 513–29.
- (82) Adman, E. T.; Godden, J. W.; Turley, S. *J. Biol. Chem.* **1995**, *270*, 27458–74.
- (83) Libby, E.; Averill, B. A. *Biochem. Biophys. Res. Commun.* **1992**, *187*, 1529–35.
- (84) Suzuki, S.; Kohzuma, T.; Deligeer; Yamaguchi, K.; Nakamura, N.; Shidara, S.; Kobayashi, K.; Tagawa, S. *J. Am. Chem. Soc.* **1994**, *116*, 11145–6.
- (85) Zumft, W. G.; Gotzmann, D. J.; Kroneck, P. M. H. *Eur. J. Biochem.* **1987**, *168*, 301–7.
- (86) Masuko, M.; Iwasaki, H.; Sakurai, T.; Suzuki, S.; Nakahara, A. *J. Biochem. (Tokyo)* **1984**, *96*, 447–54.
- (87) Suzuki, S.; Yoshimura, T.; Kohzuma, T.; Shidara, S.; Masuko, M.; Sakurai, T.; Iwasaki, H. *Biochem. Biophys. Res. Commun.* **1989**, *164*, 1366–72.
- (88) Hulse, C. L.; Yang, W.; Averill, B. A. Manuscript in preparation.
- (89) Kohzuma, T.; Shidara, S.; Suzuki, S. *Bull. Chem. Soc. Jpn.* **1994**, *67*, 138–43.
- (90) Kohzuma, T.; Takase, S.; Shidara, S.; Suzuki, S. *Chem. Lett.* **1993**, 149–52.
- (91) Abraham, Z. H. L.; Lowe, D. J.; Smith, B. E. *Biochem. J.* **1993**, *295*, 587–93.
- (92) Howes, B. D.; Abraham, Z. H. L.; Lowe, D. J.; Bruser, T.; Eady, R. R.; Smith, B. E. *Biochemistry* **1994**, *33*, 3171–7.
- (93) Strange, R. W.; Dodd, F. E.; Abraham, Z. H. L.; Grossmann, J. G.; Bruser, T.; Eady, R. R.; Smith, B. E.; Hasnain, S. S. *Nature Struct. Biol.* **1995**, *2*, 287–92.
- (94) Hulse, C. L.; Averill, B. A. *J. Am. Chem. Soc.* **1989**, *111*, 2322–3.
- (95) Averill, B. A. *Angew. Chem. Int. Ed. Engl.* **1994**, *33*, 2003–4.
- (96) Tolman, W. B. *Inorg. Chem.* **1991**, *30*, 4877–80.
- (97) Halfen, J. A.; Mahapatra, S.; Olmstead, M. M.; Tolman, W. B. *J. Am. Chem. Soc.* **1994**, *116*, 2173–4.
- (98) Halfen, J. A.; Mahapatra, S.; Wilkinson, E. C.; Gengenbach, A. J.; Young, V. G., Jr.; Que, L., Jr.; Tolman, W. B. *J. Am. Chem. Soc.* **1996**, *118*, 763–76.
- (99) Halfen, J. A.; Tolman, W. B. *J. Am. Chem. Soc.* **1994**, *116*, 5475–6.
- (100) Murphy, M. E. P.; Turley, S.; Kukimoto, M.; Nishiyama, M.; Horinouchi, S.; Sasaki, H.; Tanokura, M.; Adman, E. T. *Biochemistry* **1995**, *34*, 12107–17.
- (101) Jackson, M. A.; Tiedje, J. M.; Averill, B. A. *FEBS Lett.* **1991**, *291*, 41–4.
- (102) Ruggiero, C. E.; Carrier, S. M.; Tolman, W. B. *Angew. Chem. Int. Ed. Engl.* **1994**, *33*, 895–7.
- (103) Heiss, B.; Frunzke, K.; Zumft, W. G. *J. Bacteriol.* **1989**, *171*, 3288–97.
- (104) Kastrau, D. H. W.; Heiss, B.; Kroneck, P. M. H.; Zumft, W. G. *Eur. J. Biochem.* **1994**, *222*, 293–303.
- (105) Carr, G. J.; Ferguson, S. J. *Biochem. J.* **1990**, *269*, 423–9.
- (106) Dermastia, M.; Turk, T.; Hollocher, T. C. *J. Biol. Chem.* **1991**, *266*, 10899–905.
- (107) Jones, A. M.; Hollocher, T. C. *Biochim. Biophys. Acta* **1993**, *1144*, 359–66.
- (108) Ye, R. W.; Averill, B. A.; Tiedje, J. M. *J. Bacteriol.* **1992**, *174*, 6653–8.
- (109) Ye, R. W.; Arunakumari, A.; Averill, B. A.; Tiedje, J. M. *J. Bacteriol.* **1992**, *174*, 2560–4.
- (110) Turk, T.; Hollocher, T. C. *Biochem. Biophys. Res. Commun.* **1992**, *183*, 983–8.
- (111) Strother, V. L.; Ye, R.; Tiedje, J. M.; Averill, B. A. Manuscript in preparation.
- (112) Zhao, X.-J.; Sampath, V.; Caughey, W. S. *Biochem. Biophys. Res. Commun.* **1995**, *212*, 1054–60.
- (113) Paul, P. P.; Karlin, K. D. *J. Am. Chem. Soc.* **1991**, *113*, 6331–2.
- (114) Eisenberg, R.; Meyer, C. D. *Acc. Chem. Res.* **1975**, *8*, 26–34.
- (115) Bottomley, F. In *Reactions of Coordinated Ligands*; Braterman, B. S., Ed.; Plenum Publishing Corporation: New York, 1989; Vol. 2, pp 115–222.
- (116) Zumft, W. G.; Braun, C.; Cuypers, H. *Eur. J. Biochem.* **1994**, *219*, 481–90.
- (117) Oost van der, J.; de Boer, A. P. N.; de Gier, J.-W. L.; Zumft, W. G.; Stouthamer, A. H.; Spanning van, R. J. M. *FEMS Microbiol. Lett.* **1994**, *121*, 1–10.
- (118) Saraste, M.; Castresana, J. *FEBS Lett.* **1994**, *341*, 1–4.
- (119) Martens, C. F.; Murthy, N. N.; Obias, H. V.; Karlin, K. D. *J. Chem. Soc. Chem. Commun.* **1996**, 629–30.
- (120) Robertson, G. P.; Tiedje, J. M. *Soil Biol. Biochem.* **1987**, *19*, 187–93.
- (121) Tanimoto, T.; Hatano, K.-H.; Kim, D. H.; Uchiyama, H.; Shoun, H. *FEMS Microbiol. Lett.* **1992**, *93*, 177–80.
- (122) Garber, E. A. E.; Hollocher, T. C. *J. Biol. Chem.* **1982**, *257*, 8091–7.
- (123) Kobayashi, M.; Shoun, H. *J. Biol. Chem.* **1995**, *270*, 4146–51.
- (124) Shoun, H.; Kim, D.; Uchiyama, H.; Sugiyama, J. *FEMS Microbiol. Lett.* **1992**, *94*, 277–82.
- (125) Shoun, H.; Sudo, Y.; Seto, Y.; Beppu, T. *J. Biochem. (Tokyo)* **1983**, *94*, 1219–29.
- (126) Shoun, H.; Tanimoto, T. *J. Biol. Chem.* **1991**, *266*, 11078–82.
- (127) Kizawa, H.; Tomura, D.; Oda, M.; Fukamizu, A.; Hoshino, T.; Gotoh, O.; Yasui, T.; Shoun, H. *J. Biol. Chem.* **1991**, *266*, 10632–7.
- (128) Nakahara, K.; Shoun, H.; Adachi, S.-I.; Iizuka, T.; Shiro, Y. *J. Mol. Biol.* **1994**, *239*, 158–9.
- (129) Shiro, Y.; Kato, M.; Nakahara, K.; Shoun, H. *Biochemistry* **1994**, *33*, 8673–7.
- (130) Shiro, Y.; Fujii, M.; Isogai, Y.; Adachi, S.; Iizuka, T.; Obayashi, E.; Makino, R.; Nakahara, K.; Shoun, H. *Biochemistry* **1995**, *34*, 9052–8.
- (131) Shiro, Y.; Fujii, M.; Iizuka, T.; Adachi, S.-i.; Tsukamoto, K.; Nakahara, K.; Shoun, H. *J. Biol. Chem.* **1995**, *270*, 1617–23.
- (132) Nakahara, K.; Tanimoto, T.; Hatano, K.-I.; Usuda, K.; Shoun, H. *J. Biol. Chem.* **1993**, *268*, 8350–5.
- (133) Obika, O.; Tomura, D.; Fukamizu, A.; Shoun, H. *Biochem. Biophys. Res. Commun.* **1993**, *196*, 1255–60.
- (134) Kakutani, T.; Watanabe, H.; Arime, K.; Beppu, T. *J. Biochem. (Tokyo)* **1981**, *89*, 453–61.
- (135) Liu, M. Y.; Liu, M. C.; Payne, W. J.; LeGall, J. *J. Bacteriol.* **1986**, *166*, 604–608.
- (136) Denariaz, G.; Payne, W. J.; LeGall, J. *Biochim. Biophys. Acta* **1991**, *1056*, 225–32.
- (137) Michalski, W. P.; Nicholas, D. J. D. *Biochim. Biophys. Acta* **1985**, *828*, 130–7.

CR950056P